



DUPLEX TANK MOUNTED DRY ROTARY VANE MEDICAL VACUUM SYSTEMS 3 THROUGH 7.5 HP

The EMSE CORPORATION tank mounted Medical Vacuum system is a completely packaged NFPA 99 and NEC compliant assembly featuring dry rotary vane vacuum pumps, U.L. listed control cabinet, an ASME receiver and the accessories required to meet and exceed the current code requirements. All components are piped and wired to single-point service connections. The only field connections are air intake, air discharge and power at the control panel. All interconnecting piping and wiring is complete and operationally tested prior to shipment. Liquid tight conduit, fittings and junction boxes are provided for all control and power wiring.

The medical vacuum pumps are continuous duty, oil-less, rotary vane, air-cooled. Each vacuum pump is driven by a 3 phase, 60 cycle, TEFC NEMA C-face motor.

The system includes a vacuum receiver of ASME construction rated for 200 PSI MWP. The tank includes a vacuum gauge, valved by-pass and manual tank drain.

Each vacuum pump is supplied with an inlet check valve, inlet isolation valve, inlet filter screen, vacuum switch, inlet and discharge flexible connectors and a shut-off cock for gauge and vacuum switches.

The system includes a UL listed control panel in a NEMA 12 enclosure. The panel includes the following standard accessories for **each** pump: externally operable circuit breaker with a door interlock, control circuit transformer with fused primary and secondary coils, H-O-A switch, run light, hour meter, magnetic starter with 3 leg overload protection, reset switch and minimum run timer to prevent short cycle operation. The panel is equipped with a multiple position selector switch for selection of normal operation (automatic alternation) or manual selection of lead and lag pumps, if one pump is taken out of service for scheduled maintenance. All control circuit components are plug-in type for quick and easy replacement without re-wiring or a system shut-down.

Local "Backup in use" audible and visual alarms are provided per NFPA 99. The alarm includes an indicating light as well as the horn. The audible alarm can be acknowledged with the "Silence" button. The visual alarm will remain energized until the problem has been corrected. Each alarm function includes dry contacts for connection to the master alarm. All control and alarm functions remain energized while any vacuum pump remains electrically on-line.



Field adjustable control switches are pre-set to operate the lead vacuum pump between 19" Hg and 24" Hg, the lag pump between 18" Hg and 23" Hg. The stand-by vacuum pump will automatically start at 16" Hg if the lead vacuum pump fails to operate.

The Medical Vacuum system is guaranteed by the manufacturer for a period of 12 months from the date of start-up or 18 months from the date of shipment (whichever comes first) against defects in design, materials, or construction.

Optional System Accessories

(only checked options will be supplied)

- Rust protection receiver lining
- Galvanized receiver
- Receiver gauge glass

**DUPLEX TANK MOUNTED DRY
ROTARY VANE MEDICAL VACUUM SYSTEMS
3 THROUGH 7.5 HP
LAYOUT AND PERFORMANCE TABLE**

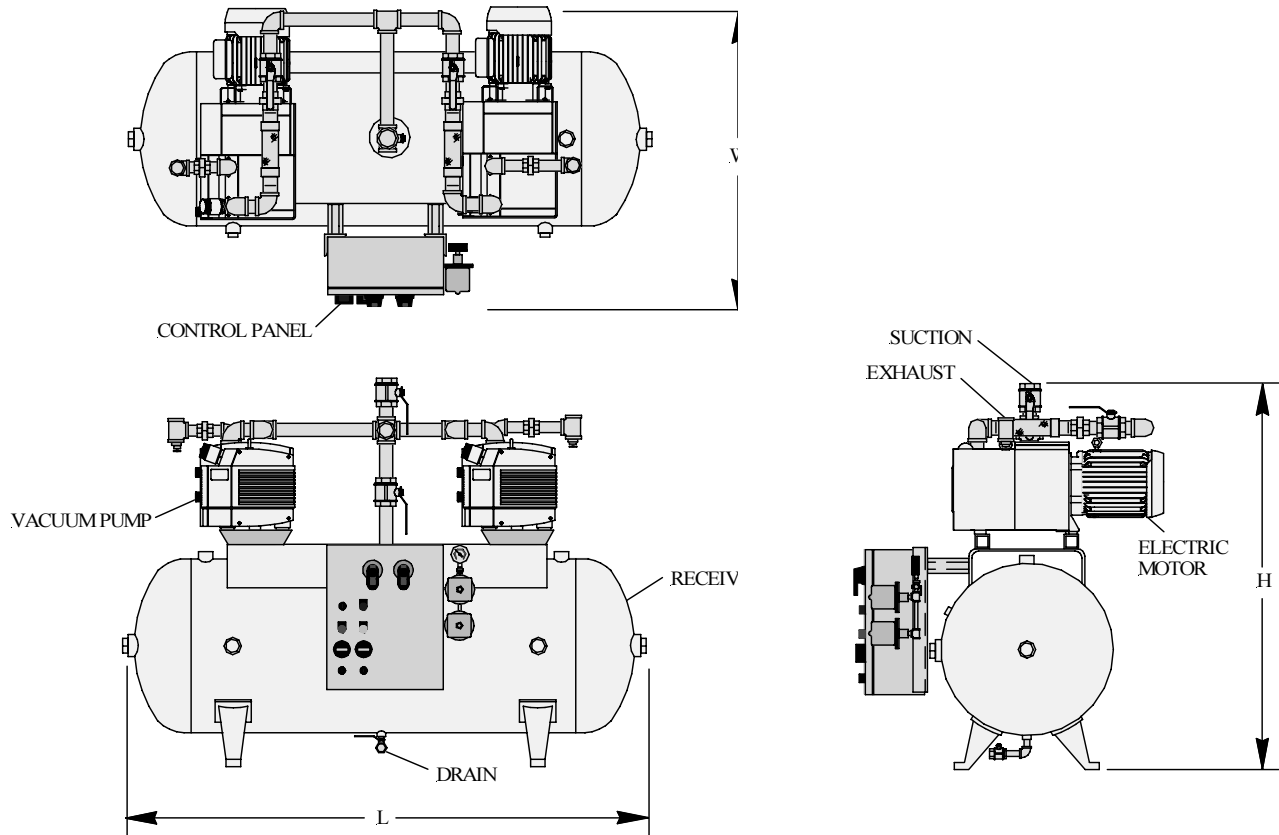

System Model Number	Horsepower		Capacity SCFM (Each Pump)		Suct. Conn.	Exh. Conn.	Tank (Gal.)	Dimensions, In.			Weight Lbs.
	Each	Total	19" Hg	24" Hg				L	W	H	
1DOB3HT120	3	6	12.0	4.4	1"	1"	120	72	40	58	965
1DOB5T120	5	10	15.7	7.5	1"	1"	120	72	41	58	990
1DOB5HT120	5	10	21.2	9.5	1-1/2"	1-1/4"	120	72	41	58	1025
1DOB7.5T120	7.5	15	29.0	12.3	1-1/2"	1-1/4"	120	72	45	58	1140

Notes: 1. To convert Free Air Capacity (SCFM) to Expanded Air Capacity (ACFM):
at 19" Hg multiply SCFM by 2.74
at 24" Hg multiply SCFM by 5.05
2. Maximum ambient temperature: 105°F. For higher ambient temperatures consult factory.

Power Requirements:

(Two) _____ HP Motors, 3 Phase 60 Hertz 208 v 230 v 460 v