



## TRIPLEX BASE MOUNTED WATER-LESS LIQUID RING MEDICAL VACUUM SYSTEMS

The EMSE CORPORATION continuous duty base mounted medical vacuum system is completely packaged, NFPA 99 and NEC compliant, featuring water-less, air-cooled, oil-sealed liquid ring vacuum pumps, U.L. listed control cabinet, an ASME receiver and the accessories required to meet and exceed the current code requirements. All components are piped and wired to single-point service connections. The only field connections are air intake, air discharge and power at the control panel. All interconnecting piping and wiring is complete and operationally tested prior to shipment. Liquid tight conduit, fittings and junction boxes are provided for all control and power wiring. The system is mounted on a common structural steel base.

The medical vacuum pump system requires no water. The pumps are a positive displacement, non-pulsating, liquid ring design. Standard construction is cast iron with a stainless steel shaft and mechanical seals. Each pump provides four stages of oil and smoke removal that include built-in two stage exhaust demisters with 99.9+% efficiency to provide smoke-free exhaust. The pumps are driven by 40 degree C rise, 3 phase, 60 cycle, NEMA design B induction type motors.

The system includes a vacuum receiver of ASME construction rated for 200 PSI MWP. The tank includes a vacuum gauge, valved by-pass and manual tank drain.

Each vacuum pump is supplied with an inlet check valve, inlet isolation valve, relief valve, exhaust separator with two stage exhaust demisters, sight level and back pressure indicators, separator drain valve, air-to-oil heat exchanger, oil line isolation valve, solenoid valve, temperature gauge, high temperature shut down switch, vacuum switch, inlet and discharge flexible connectors and a shut-off cock for gauge and vacuum switches.

The system includes a UL listed control panel in a NEMA 12 enclosure. The panel includes the following standard accessories for **each** pump: externally operable circuit breaker with a door interlock, control circuit transformer with fused primary and secondary coils, H-O-A switch, run light, hour meter, magnetic starter with 3 leg overload protection, reset switch and minimum run timer to prevent short cycle operation. A plug-in type programmable controller with removable terminals allows quick and easy replacement in the field. The system is designed to function even if the PLC fails. If one of the pumps is out of service the system control shall omit that pump from the alternating cycle, automatically alternating between the remaining pumps. The system shall revert to normal automatic alternation when the condition is corrected.



The system is also supplied with forced time alternation in the event the pump is unable to satisfy the demand in 30 minutes.

Local audible and visual alarms are provided per NFPA 99 for "Reserve in use" and thermal malfunction. The alarms include indicating lights and horn. The thermal malfunction shut-down is provided with a manual reset. The audible alarm can be cancelled with the "Silence" button. The visual alarm remains energized until the problem is corrected. Each alarm function includes dry contacts for connection to the master alarm. All control and alarm functions remain energized while any vacuum pump remains electrically on-line.

Field adjustable control switches are pre-set to operate the lead vacuum pump between 20" Hg and 25" Hg and the lag pump between 18" Hg and 25" Hg. The stand-by vacuum pump will automatically start at 18" Hg if one of the other vacuum pumps fails to operate.

The medical vacuum system and its component parts will undergo a complete electric and pneumatic test prior to shipment.

The medical vacuum system is guaranteed by the manufacturer for a period of 18 months from the date of start-up or 24 months from the date of shipment (whichever comes first) against defects in design, materials, or construction. In addition, the **pumps are guaranteed for 5 years** from the date of shipment.

### Optional System Accessories

(only checked options will be supplied)

- Rust protection receiver lining
- Galvanized receiver
- Receiver gauge glass

# TRIPLEX BASE MOUNTED WATER-LESS LIQUID RING MEDICAL VACUUM SYSTEMS LAYOUT AND PERFORMANCE TABLE

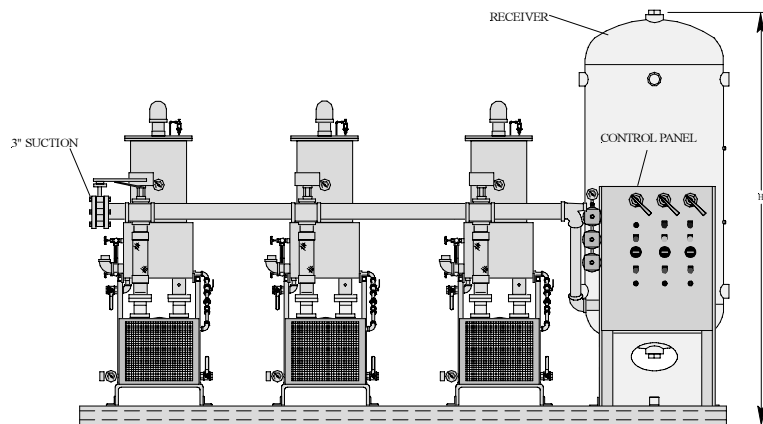
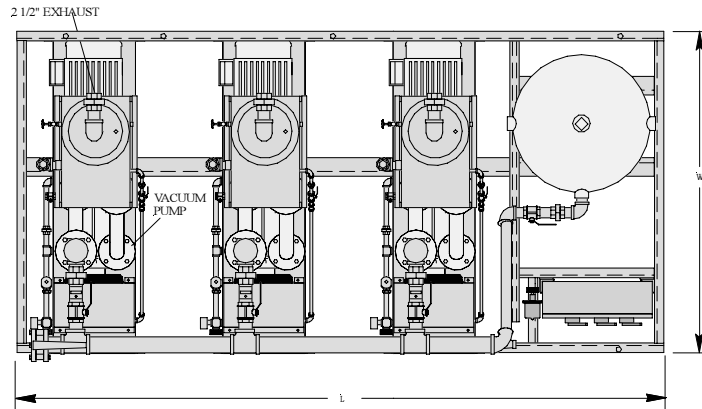

Model Number	Motor Horsepower		Performance Data SCFM, Each Pump		Tank Size Gal	Water Usage GPM	Dimensions Inches			System Weight Lbs.
	Each	Total	19" Hg	25" Hg			L	W	H	
1TWOT15B200	15	45	87.6	39.3	200	None	140	65	86	3340
1TWOT20B200	20	60	113.1	47.5	200	None	140	70	86	3890

- Notes:**
- To convert Free Air Capacity (SCFM) to Expanded Air Capacity (ACFM):  
 at 19" Hg multiply SCFM by 2.74  
 at 25" Hg multiply SCFM by 6.1
  - Maximum ambient temperature: 95°F. For higher ambient temperatures consult factory.

### Power Requirements:

(Three) \_\_\_\_\_ HP Motors, 3 Phase 60 Hertz     208 v     230 v     460 v