



## DUPLEX STACK MOUNTED HIGH EFFICIENCY DRY CLAW MEDICAL VACUUM SYSTEMS 5 THROUGH 8.5 HP

The EMSE CORPORATION stack mounted Medical Vacuum system is a completely packaged NFPA 99 and NEC compliant assembly featuring high efficiency dry claw vacuum pumps, U.L. listed control cabinet, an ASME receiver and the accessories required to meet and exceed the current code requirements. All components are piped and wired to single-point service connections. The only field connections are air intake, air discharge and power at the control panel. All interconnecting piping as well as wiring is complete and operationally tested prior to shipment. Liquid tight conduit, fittings and junction boxes are provided for all control and power wiring.

The medical vacuum pumps are continuous duty, high efficiency, oil-less, frictionless compression claw type, with intake filters and exhaust mufflers. Each vacuum pump is driven by a 3 phase, 60 cycle, TEFC NEMA C-face motor.

The system includes a vacuum receiver of ASME construction rated for 200PSI MWP. The tank is equipped with a vacuum gauge, valved by-pass and manual tank drain.

Each vacuum pump is supplied with an inlet check valve, inlet isolation valve, safety relief valve, inlet filter, vacuum switch, inlet and discharge flexible connectors and a shut-off cock for gauge and vacuum switches.

The system includes a UL listed control panel in a NEMA 12 enclosure. The panel includes the following for **each** pump: externally operable circuit breaker with a door interlock, control circuit transformer with fused primary and secondary coils, H-O-A switch, run light, hour meter, magnetic starter with 3 leg overload protection, reset switch and minimum run timer to prevent short cycle operation. The panel is equipped with a multiple position selector switch for selection of normal operation (automatic alternation) or manual selection of lead and lag pumps if a pump is taken out of service for scheduled maintenance. All control circuit components are plug-in type for quick and easy replacement without re-wiring or a system shutdown.

Local "Backup in use" audible and visual alarms are provided per NFPA 99. The alarm includes an indicating light and horn. The audible alarm can be cancelled with the "Silence" button. The visual alarm remains energized until the problem is corrected. Each alarm function includes dry contacts for connection to the master alarm. All control and alarm functions remain energized while any vacuum pump remains electrically on-line.



Field adjustable control switches are pre-set to operate the lead vacuum pump between 18" Hg and 23" Hg. The stand-by vacuum pump will automatically start at 17" Hg if one of the other vacuum pumps fails to operate.

The Medical Vacuum system and its component parts will undergo a complete electric and pneumatic test prior to shipment.

The Medical Vacuum system is guaranteed by the manufacturer for a period of 24 months from the date of start-up or 30 months from the date of shipment (whichever comes first) against defects in design, materials, or construction.

### Optional System Accessories

(only checked options will be supplied)

- Rust protection receiver lining
- Galvanized receiver
- External intake filters
- Thermal malfunction shut-down with manual reset and alarm lights
- Oxygen assured
- Variable speed drive

**DUPLEX STACK MOUNTED HIGH EFFICIENCY  
DRY CLAW MEDICAL VACUUM SYSTEMS  
5 THROUGH 8.5 HP  
LAYOUT AND PERFORMANCE TABLE**

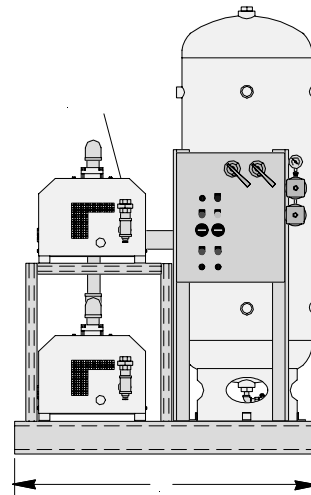
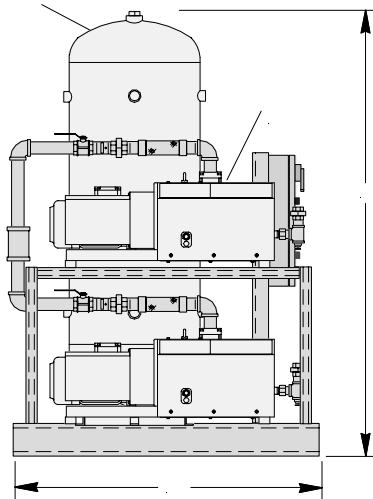
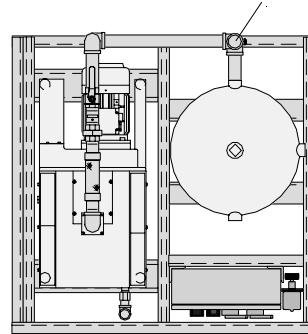

System Model Number	Horsepower		Capacity SCFM (Each Pump) @ 19" Hg	Suct. Conn.	Exh. Conn.	Tank (Gal.)	Dimensions, In.			Weight Lbs.
	Each	Total					L	W	H	
1DCB5S120	5	10	38.0	1.25"	1"	120	56	56	80	1995
1DCB7.5S120	7.5	15	52.0	2"	1"	120	56	56	80	2030
1DCB7.5HS120	7.5	15	69.0	2"	1"	120	56	56	80	2050
1DCB8.5S120	8.5	17	77.0	2"	1.25"	120	58	56	80	2060
1DCB8.5S200	8.5	17	77.0	2"	1.25"	200	64	62	86	2420

**Notes:** 1. To convert Free Air Capacity (SCFM) to Expanded Air Capacity (ACFM):  
at 19" Hg multiply SCFM by 2.74  
2. Maximum ambient temperature: 100° F. For higher ambient temperatures consult factory

**Power Requirements:**

(Two) \_\_\_\_\_ HP Motors, 3 Phase 60 Hertz     208 v     230 v     460 v