



TRIPLEX STACK MOUNTED HIGH EFFICIENCY DRY CLAW MEDICAL VACUUM SYSTEMS 10 HP

The EMSE CORPORATION stack mounted Medical Vacuum system is a completely packaged NFPA 99 and NEC compliant assembly featuring high efficiency dry claw vacuum pumps, U.L. listed control cabinet, an ASME receiver and the accessories required to meet and exceed the current code requirements. All components are piped and wired to single-point service connections. The only field connections are air intake, air discharge and power at the control panel. All interconnecting piping and wiring is complete and operationally tested prior to shipment. Liquid tight conduit, fittings and junction boxes are provided for all control and power wiring.

The medical vacuum pumps are continuous duty, high efficiency, oil-less, frictionless, compression rotary claw, with intake filters and exhaust silencers. Each vacuum pump is driven by a 3 phase, 60 cycle, TEFC NEMA C-face motor. The system includes a vacuum receiver of ASME construction rated for 200 PSI MWP. The tank includes a vacuum gauge, valved by-pass and manual tank drain.

Each vacuum pump is supplied with an inlet check valve, inlet isolation valve, safety relief valve, inlet filter, vacuum control switch, inlet and discharge flexible connectors and a shut-off cock for gauge and vacuum switch.

The system includes a UL listed control panel in a NEMA 12 enclosure. The panel includes the following standard accessories for **each** pump: externally operable circuit breaker with a door interlock, control circuit transformer with fused primary and secondary coils, H-O-A switch, run light, hour meter, magnetic starter with 3 leg overload protection and reset switch and minimum run timer to prevent short cycle operation. A plug-in type programmable controller with removable terminals allows quick and easy replacement in the field. The system is designed to function even if the PLC fails. If one of the pumps is out of service the system control shall omit that pump from the alternating cycle, automatically alternating between the remaining pumps. The system shall revert to normal automatic alternation when the condition is corrected. The system is also supplied with forced time alternation in the event the pump is unable to satisfy the demand in 30 minutes.

Local "Backup in use" audible and visual alarms are provided per NFPA 99. The alarm includes an indicating light and horn. The audible alarm can be cancelled with the "Silence" button. The visual alarm remains energized until the problem is corrected. Each alarm function includes dry contacts for connection to the master alarm.



All control and alarm functions remain energized while any vacuum pump remains electrically on-line.

Field adjustable control switches are pre-set to operate the lead vacuum pump between 19" Hg and 23" Hg and the lag pump between 18" Hg and 22" Hg. The stand-by vacuum pump will automatically start at 16" Hg if one of the other vacuum pumps fails to operate.

The Medical Vacuum system and its component parts undergo a complete electric and pneumatic test prior to shipment.

The Medical Vacuum system is guaranteed by the manufacturer for a period of 24 months from the date of start-up or 30 months from the date of shipment (whichever comes first) against defects in design, materials, or construction.

Optional System Accessories

(only checked options will be supplied)

- Rust protection receiver lining
- Galvanized receiver
- High inlet vacuum shut-down
- External intake filters
- Thermal malfunction shut-down with manual reset and alarm lights
- Oxygen assured
- Variable speed drive

**TRIPLEX STACK MOUNTED HIGH EFFICIENCY
 DRY CLAW MEDICAL VACUUM SYSTEMS
 10 HP
 LAYOUT AND PERFORMANCE TABLE**

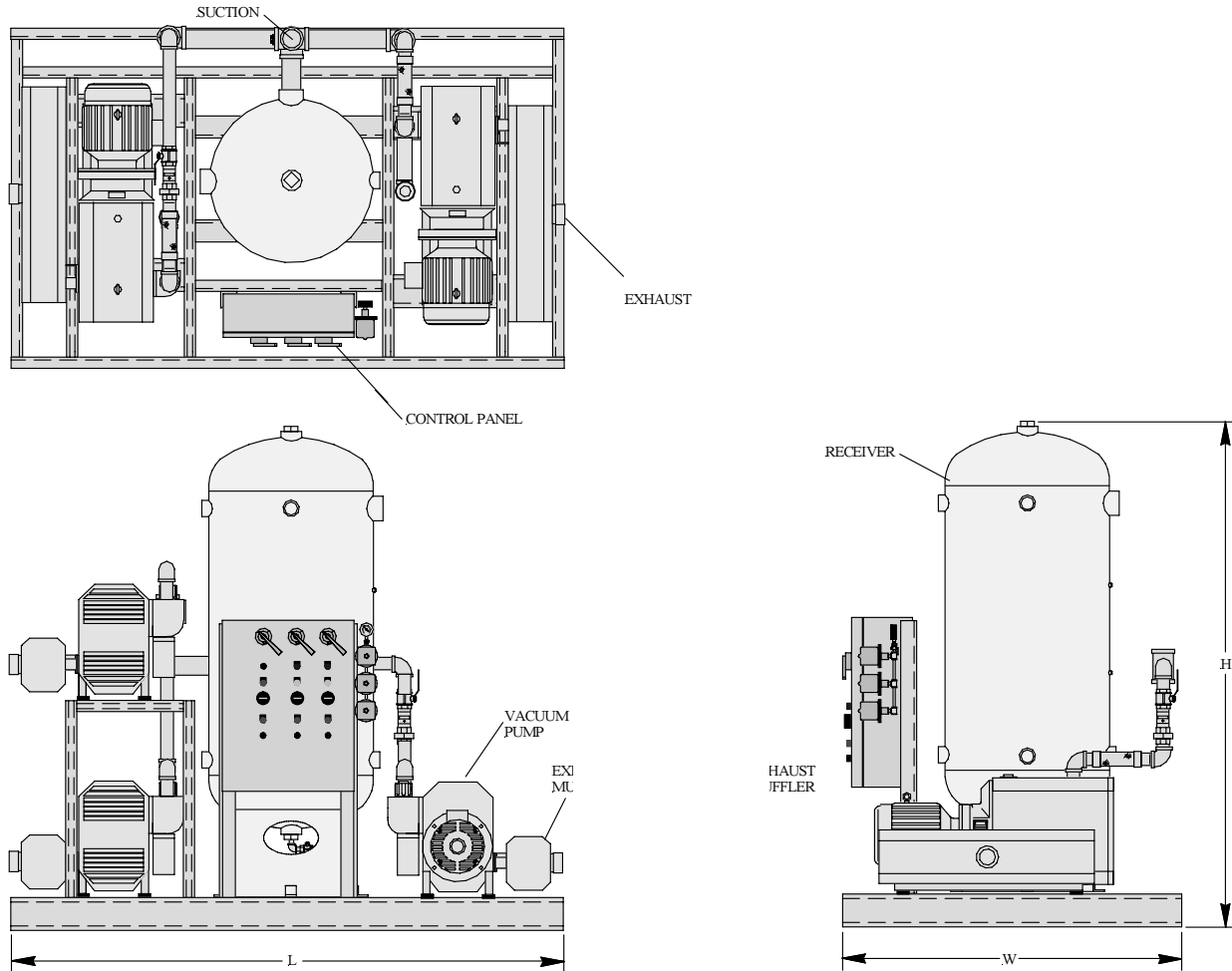

System Model Number	Horsepower		Capacity SCFM (Each Pump) @19" Hg	Suct. Conn.	Exh. Conn.	Tank (Gal.)	Dimensions, In.			Weight Lbs.
	Each	Total					L	W	H	
1TCR10S200	10	30	89.4	4"	3"	200	102	62	88	3110

- Notes:** 1. To convert Free Air Capacity (SCFM) to Expanded Air Capacity (ACFM):
 at 19" Hg multiply SCFM by 2.74
 2. Maximum ambient temperature: 100° F. For higher ambient temperatures consult factory

Power Requirements:

(Three) _____ HP Motors, 3 Phase 60 Hertz 208 v 230 v 460 v