



TRIPLEX MODULAR MEDICAL SCROLL AIR PLANTS WITH DESICCANT AIR DRYERS 15 HP

The EMSE CORPORATION continuous duty Medical Air Plant is stack mounted, completely packaged, NFPA 99 and NEC compliant assembly with 100% oil-less, rotary scroll air compressors, U.L. listed control cabinet, an ASME receiver, dual desiccant air dryers with purge control, dual 0.5 micron pre-filters, dual 0.5 micron after-filters, dual line pressure regulators, dew point monitor, CO monitor and all accessories required to meet and exceed the current code. All components are piped and wired to single-point service connections. The only field connections are air intake, air discharge and power at the control panel. All interconnecting piping and wiring is complete and operationally tested prior to shipment. Liquid tight conduit, fittings and junction boxes are provided for all control and power wiring. **After testing the system will be separated into 34" modules for ease of installation.**

The medical air compressors are rotary oil-less scroll, air-cooled design. They are dynamically balanced for very low noise levels and little vibration. **No oil is used in operation of the compressors, so the discharge air is 100% oil-free.** Cooling is provided with an integral radial fan. Compressors are V-belt driven by 3 phase, 60 cycle, 3550 RPM, NEMA design B motors. Included are slide bases for belt tension adjustment and totally enclosed OSHA approved belt guards.

The system includes a corrosion resistant receiver of ASME construction rated for 200 PSI MWP service. The tank includes a pressure gauge, safety relief valve, 3 way by-pass, gauge glass and an automatic electronic drain with manual override.

Standard equipment includes air cooled aftercoolers, compressor discharge check valves, safety relief valves, intake and discharge flexible connectors, solenoid drain valves, isolation valves, high discharge temperature shut-down switches, pressure control switches, a shut-off cock for gauge and switches.

The dryer assembly consists of two identical banks of air treatment equipment, piped in parallel and provided with valves to by-pass either bank without sacrificing air quality. Each desiccant air dryer is sized for 100% of the system NFPA capacity. The dryer is designed to provide a maximum dew point below +32°F per NFPA 99. Built-in purge saver control automatically minimizes the amount of purge air to match the variable air flow. Each dryer is equipped with a 0.5 micron pre-filter with electronic drain and element change indicator, 0.5 micron after-filter with element change indicator and a pressure regulator.

Digital dew point and CO monitors with alarm set points at 39°F and 10 PPM are provided. A "demand check" for maintenance is included per current NFPA 99 for each instrument.

The system includes a UL labeled control panel in a NEMA 12 enclosure. The panel includes the following: externally



operable circuit breakers with a door interlock, control circuit transformers with fused primary and secondary coils, H-O-A switches, run lights, hour meters and magnetic starters with 3 leg overload protection and reset switch.

A plug-in type programmable controller with removable terminals allows quick and easy replacement in the field. The system is designed to function even if the PLC fails. If one of the compressors is out of service, the system control shall omit that unit from the alternating cycle, automatically alternating between the remaining compressors. The system shall revert to normal automatic alternation when the condition is corrected. The system is also supplied with forced time alternation in the event the compressor is unable to satisfy the demand in 30 minutes.

Local audible and visual alarms are provided per NFPA 99 for compressor thermal malfunction, "Backup in use", high dew point and high carbon monoxide. The alarms include indicating lights and a horn. The thermal malfunction shut-down is provided with a manual reset. The audible alarm can be cancelled with the "Silence" button. The visual alarm will remain energized until the problem is corrected. Each alarm function includes dry contacts for connection to the master alarm. All control and alarm functions remain energized while any compressor remains electrically on-line. Field adjustable control switches are pre-set to operate the lead compressor module between 100 PSIG and 120 PSIG, the lag compressor module between 95 PSIG and 115 PSIG. The stand-by compressor will automatically start at 90 PSIG if one of the other compressors fails to operate.

The Medical Air Plant is guaranteed by the manufacturer for a period of 12 months from the date of start-up or 18 months from the date of shipment (whichever comes first) against defects in design, materials, or construction. In addition, the compressors are guaranteed for 36 months from the date of shipment.

TRIPLEX MODULAR SCROLL MEDICAL AIR PLANTS WITH DESICCANT AIR DRYERS 15 HP LAYOUT AND PERFORMANCE TABLE

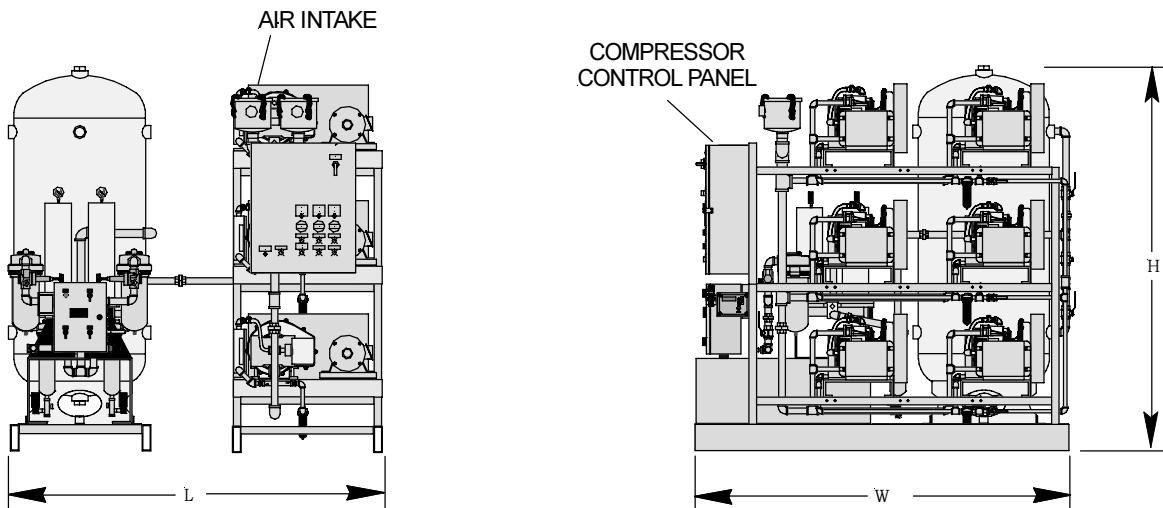
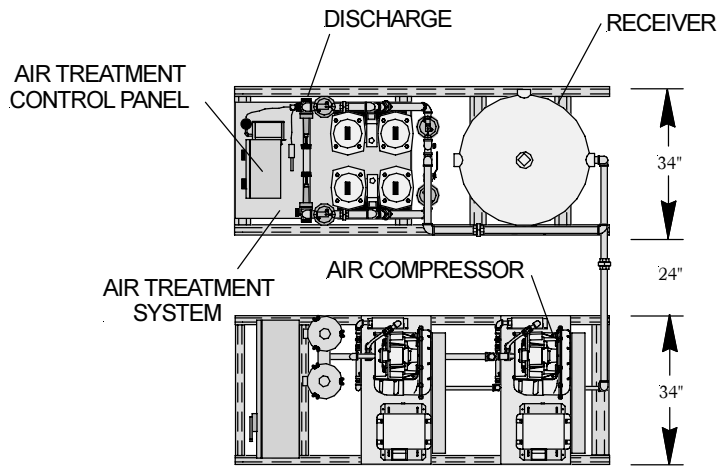

System	Horsepower		System Capacity ICFM ¹		Disch. Conn.	Tank (Gal.)	Dimensions, In.			Weight Lbs.
	Each	Total	50 PSIG	120 PSIG			L	W	H	
3TOHS15MS200D	15	45	100.8	96.0	1"	200	92	86	87	3550

Notes:

1. Capacity shown is NFPA system capacity with reserve compressor on stand-by.
2. Maximum ambient temperature: 100°F. For higher ambient temperatures consult factory.

Power Requirements:

(Three) _____ HP Motors, 3 Phase 60 Hertz 208 v 230 v 460 v