



DUPLEX BASE MOUNTED "Q" SERIES MEDICAL AIR SYSTEMS 20 THROUGH 30 HP (2 STAGE)

The EMSE CORPORATION continuous duty Medical Air system is a completely packaged NFPA 99 and NEC compliant assembly featuring oil-less air compressors, U.L. listed electrical control cabinet, ASME receiver and all the accessories required to meet and exceed the current code requirements. All components are pre-piped and pre-wired to single-point service connections. The only field connections are air intake, air discharge and power at the control panel. All interconnecting piping and wiring is complete and operationally tested prior to shipment. Liquid tight conduit, fittings and junction boxes are provided for all control and power wiring. The entire system including the receiver is mounted on a common structural steel base.

The medical air compressors are oil-less, reciprocating, air-cooled design. The air compressors feature a cast iron crankcase, teflon-composite compression and rider rings, lubricated and sealed bearings, stainless steel reed valves, non-asbestos gaskets. **No oil is used in operation of the compressors. The discharge air is 100% oil-free.** Cooling is provided by a fan compressor pulley with air shroud.

Compressors are V-belt driven by 3 phase, 60 cycle, 1750 RPM, NEMA design B motors.

The system includes an ASME receiver rated for 200 PSI MWP service. The tank is equipped with a pressure gauge, safety relief valve, 3 way by-pass, gauge glass and automatic tank drain with manual override.

Also included are check valves, safety relief valves, intake and discharge flexible connectors, solenoid unloaders, isolation valves, high discharge temperature shut-down switches, pressure switches and a shut-off cock for gauge and switches.

The system includes a UL listed control panel in a NEMA 12 enclosure. The panel includes the following for **each** pump: externally operable circuit breaker with a door interlock, control circuit transformer with fused primary and secondary coils, H-O-A switch, run light, hour meter and magnetic starter with 3 leg overload protection and reset switch. The panel is equipped with a multiple position selector switch for selection of normal operation (automatic alternation) or manual selection of lead and lag pumps if a pump is taken out of service due to scheduled maintenance.

Local audible and visual alarms are provided per NFPA 99 for compressor thermal malfunction and "Backup in use". The alarms include indicating lights and a horn. The thermal malfunction shut-down is provided with a manual reset. The audible alarm can be cancelled with the "Si-



lence" button. The visual alarm remains energized until the problem is corrected. Each alarm function includes dry contacts for connection to the master alarm. All control and alarm functions remain energized while any compressor in the system is on-line.

Field adjustable control switches are pre-set to operate the lead compressor between 100 PSIG and 125 PSIG. The lag compressor will automatically start at 95 PSIG if the lead compressor fails to operate.

The Medical Air system is guaranteed by the manufacturer for a period of 12 months from the date of start-up or 18 months from the date of shipment (whichever comes first) against defects in design, materials, or construction.

Optional System Accessories

(only checked options will be supplied)

- "Dura-coat" rust protection receiver lining
- Galvanized receiver
- Air-cooled aftercoolers
- Dual medical air treatment system with refrigerated air dryers
- Dual medical air treatment system with desiccant air dryers

**DUPLEX BASE MOUNTED
"Q" SERIES MEDICAL AIR SYSTEMS
20 THROUGH 30 HP (2-STAGE)
LAYOUT AND PERFORMANCE TABLE**

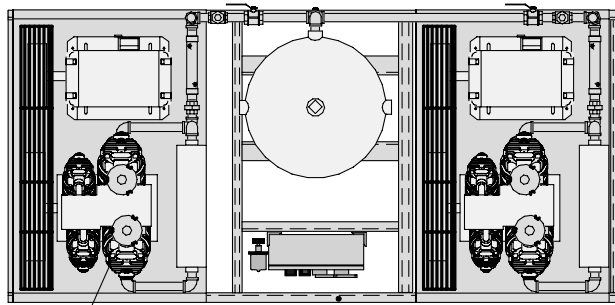

AIR COMPRESSOR

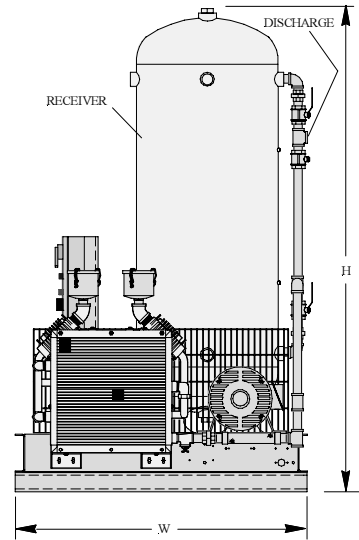
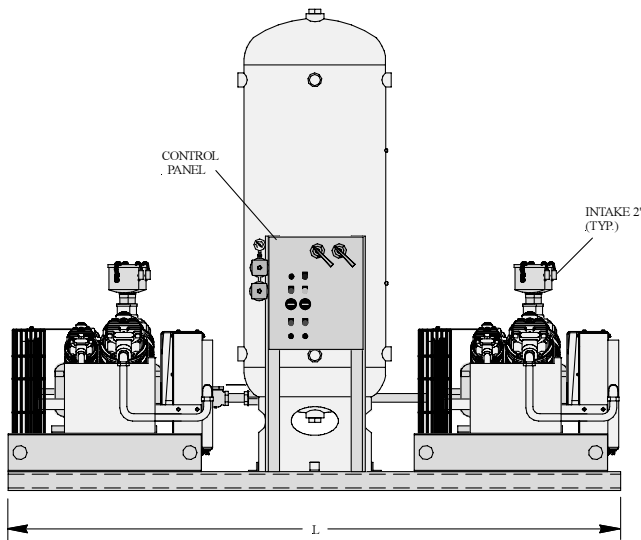

System Model Number	Horsepower		Capacity SCFM (Each Pump)		Disch. Conn.	Tank (Gal.)	Dimensions, In.			Weight Lbs.
	Each	Total	100 PSIG	125 PSIG			L	W	H	
3DOQ20B240	20	40	81.5	80.1	1.5"	240	130	62	102	3880
3DOQ25B240	25	50	100.0	94.2	1.5"	240	130	62	102	4090
3DOQ30B240	30	60	114.2	104.2	1.5"	240	130	62	102	4170

Power Requirements:

(Two) _____ HP Motors, 3 Phase 60 Hertz 208 v 230 v 460 v