



DUPLEX TANK MOUNTED "X" SERIES MEDICAL AIR SYSTEMS 7.5 THROUGH 15 HP

The EMSE CORPORATION continuous duty Medical Air system is a completely packaged NFPA 99 and NEC compliant assembly featuring oil-less air compressors, U.L. listed control cabinet, ASME receiver and all the accessories required to meet and exceed the current code requirements. All components are piped and wired to single-point service connections. The only field connections are air intake, air discharge and power at the control panel. All interconnecting piping and wiring is complete and operationally tested prior to shipment. Liquid tight conduit, fittings and junction boxes are provided for all control and power wiring.

The medical air compressors are an oil-less, reciprocating, air-cooled design. Connecting rod and bearings are sealed with life-time lubrication. **No oil is used in operation of the compressors. The discharge air is 100% oil-free.** Cooling is provided with a radial fan and shroud. Compressors are V-belt driven by 3 phase, 60 cycle, 1750 RPM, NEMA design B motors. Slide bases for belt tension adjustment and totally enclosed OSHA approved belt guards are provided.

The system includes an ASME receiver rated for 200 PSI MWP service. The tank is suspended between heavy duty base supports. It is isolated from the weight of the compressors. The tank is equipped with a pressure gauge, safety relief valve, 3 way by-pass, gauge glass and electronic tank drain with manual override.

Also included are check valves, safety relief valves, intake and discharge flexible connectors, solenoid unloaders, isolation valves, high discharge temperature shut-down switches, pressure switches, and shut-off cock for gauge and switches.

The system includes a UL listed control panel in a NEMA 12 enclosure. The panel includes the following for **each** pump: externally operable circuit breaker with a door interlock, control circuit transformer with fused primary and secondary coils, H-O-A switch, run light, hour meters and magnetic starter with 3 leg overload protection and reset switch. The panel is equipped with a multiple position selector switch for selection of normal operation (automatic alternation) or manual selection of lead and lag pumps if a pump is taken out of service for scheduled maintenance.

Local audible and visual alarms are provided per NFPA 99 for compressor thermal malfunction and "Backup in use". The alarms include indicating lights and a horn. The thermal malfunction shut-down is provided with a manual



reset. The audible alarm can be cancelled with the "Silence" button. The visual alarm remains energized until the problem is corrected. Each alarm function includes dry contacts for connection to the master alarm. All control and alarm functions remain energized while any compressor remains on-line.

Field adjustable pressure switches are pre-set to operate the lead compressor between 80 PSIG and 100 PSIG. The lag compressor will automatically start at 75 PSIG if the lead compressor fails to operate.

The Medical Air system is guaranteed by the manufacturer for a period of 12 months from the date of start-up or 18 months from the date of shipment (whichever comes first) against defects in design, materials, or construction. In addition, the compressors are guaranteed for 36 months from the date of shipment.

Optional System Accessories

(only checked options will be supplied)

- "Dura-coat" rust protection receiver lining
- Galvanized receiver
- Air-cooled aftercoolers
- Dual medical air treatment system with refrigerated air dryers
- Dual medical air treatment system with desiccant air dryers

**DUPLEX TANK MOUNTED
"X" SERIES MEDICAL AIR SYSTEMS
7.5 THROUGH 15 HP
LAYOUT AND PERFORMANCE TABLE**

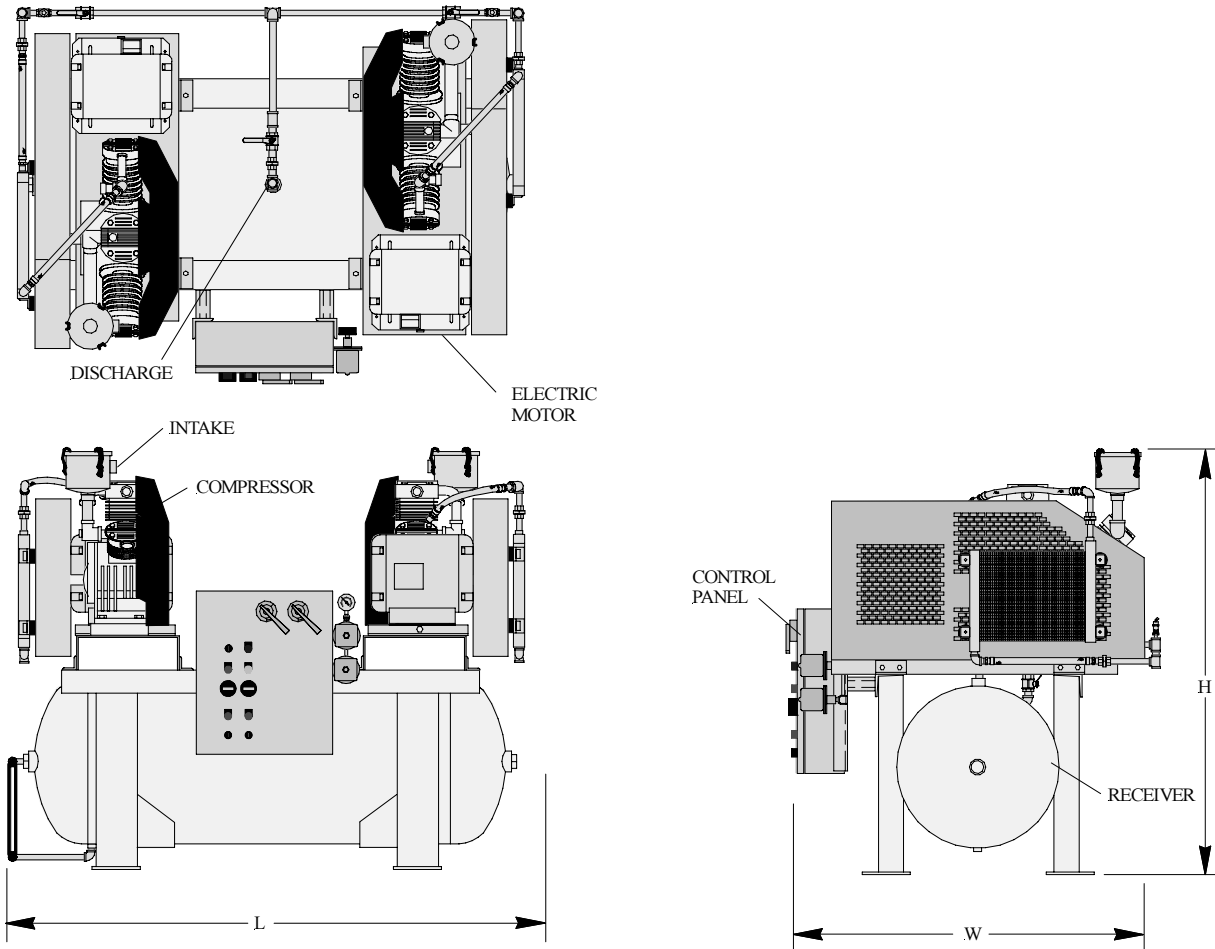

System Model Number	Horsepower		Capacity SCFM (Each Pump)		Disch. Conn.	Tank (Gal.)	Dimensions, In.			Weight Lbs.
	Each	Total	50 PSIG	100 PSIG			L	W	H	
3DOX7.5T120	7.5	15	28.6	27.6	3/4"	120	77	54	61	1130
3DOX10T120	10	20	39.2	35.0	3/4"	120	77	54	61	1150
3DOX15T120	15	30	57.0	53.5	3/4"	120	77	54	61	1350

Note: Maximum ambient temperature: 100°F. For higher ambient temperatures consult factory.

Power Requirements:

(Two) _____ HP Motors, 3 Phase 60 Hertz 208 v 230 v 460 v